



Modular fluid handling device II Patent

Infinity Turbine
LLC

[TEL] +1-608-238-6001 (Chicago)

[Email] greg@infinityturbine.com

<https://www.infinityturbine.com/patent-heat-pump-and-orc-turboshaft-for-process-cooling-and-hydraulic-power-by-cavgenix-infinity-turbine.html>

A modular fluid handling device includes at least one block having opposing block faces shaped as tessellating regular polygons, and a series of block sides therebetween. Each block includes a central bore and fluid passages extending between the block faces, and possibly ducts extending between the bore and the fluid passages. The blocks may be rapidly horizontally and/or vertically affixed with their bores and/or fluid passages in communication to form a fluid handling device having the desired configuration (e.g., with the bores and fluid passages forming a desired process flow path, fluid circuit, or the like). Star wheels and/or rotor discs can be provided within the block bores for purposes of pumping fluids flowing within the bores, and/or for purposes of deriving power from fluid flow within the bores.



This webpage QR code

PDF Version of the webpage (maximum 10 pages)

Modular fluid handling device II Patent US7726331B1

A modular fluid handling device includes at least one block having opposing block faces shaped as tessellating regular polygons, and a series of block sides therebetween. Each block includes a central bore and fluid passages extending between the block faces, and possibly ducts extending between the bore and the fluid passages. The blocks may be rapidly horizontally and/or vertically affixed with their bores and/or fluid passages in communication to form a fluid handling device having the desired configuration (e.g., with the bores and fluid passages forming a desired process flow path, fluid circuit, or the like). Star wheels and/or rotor discs can be provided within the block bores for purposes of pumping fluids flowing within the bores, and/or for purposes of deriving power from fluid flow within the bores.



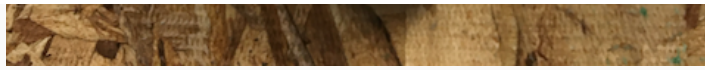

FIELD OF THE INVENTION

This document concerns an invention relating generally to devices for processing and sampling of gases and liquids, and more specifically to devices allowing rapid construction of fluid reactors, distillers, extractors, homogenizers, filtration/separation devices, process models (e.g., devices for modeling engine cycles, refrigeration cycles, etc.), and other devices for handling fluids.

FIELD OF THE INVENTION

This document concerns an invention relating generally to devices for processing and sampling of gases and liquids, and more specifically to devices allowing rapid construction of fluid reactors, distillers, extractors, homogenizers, filtration/separation devices, process models (e.g., devices for modeling engine cycles, refrigeration cycles, etc.), and other devices for handling fluids.

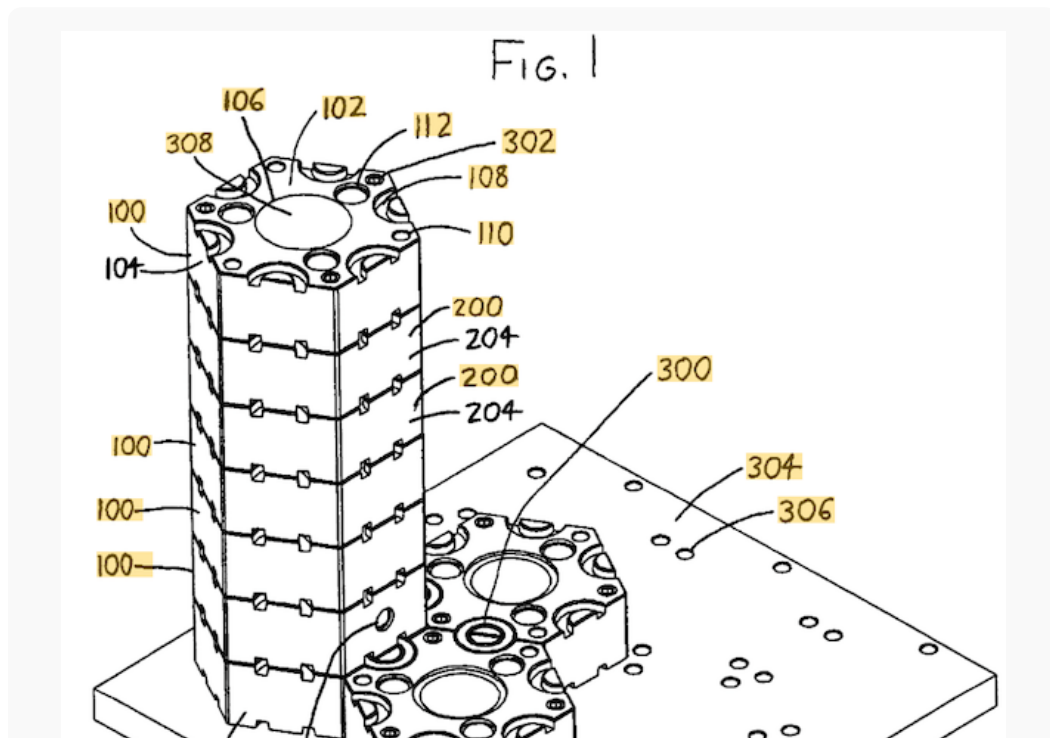

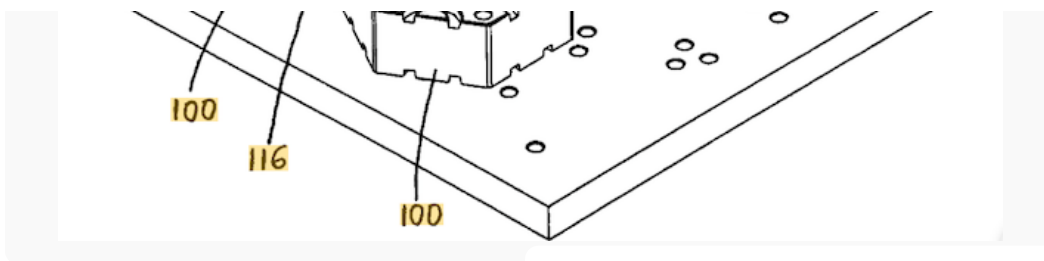

Copyright 6/30/202 Infinity Turbine LLC

BACKGROUND OF THE INVENTION

Fluid handling devices including fermenters, distillers, filtration tanks, evaporators, etc. (or combinations of these components) are exceedingly common in industry and in research labs. Researchers and engineers also often need to experiment with models for common thermodynamic cycles, e.g., refrigeration cycles (vapor compression cycle, Einstein cycle, etc.) and power cycles (Otto cycle, Diesel cycle, Brayton cycle, Rankine cycle, etc.). While it is often desirable to generate prototypes or small-scale versions of such devices, they are usually time-consuming, difficult, and expensive to construct. One approach commonly used in laboratories is to connect glassware vessels (e.g., flasks, towers, heat exchangers, etc.) with rubber tubing so that the vessels form some desired fluid process model. Even apart from the significant time and expense required for their construction, these are quite fragile, are unsuitable for pressurized processes, and are also usually unsuitable for processes involving extreme temperatures or corrosive materials owing to the weakness of the tubing. In some cases, more durable fluid handling devices can be formed from metal vessels connected with (for example) brazed copper tubing, but these involve even greater time, cost, and fabrication burdens.

A prior patent (U.S. Pat. No. 7,146,999 to Giese et al., which is incorporated by reference herein) describes a modular fluid handling system wherein modular blocks bear passageways for carrying fluids, and wherein inserts having different functionality—e.g., valve inserts, filter inserts, turbine inserts, pump inserts, heating/cooling inserts, sensor inserts, flow routing/diverting inserts, etc.—can be inserted into selected blocks. The blocks, with or without inserts, can be affixed together to construct a durable fluid handling device. This document relates to improvements and additions to the modular fluid handling system described in U.S. Pat. No. 7,146,999 to Giese et al.

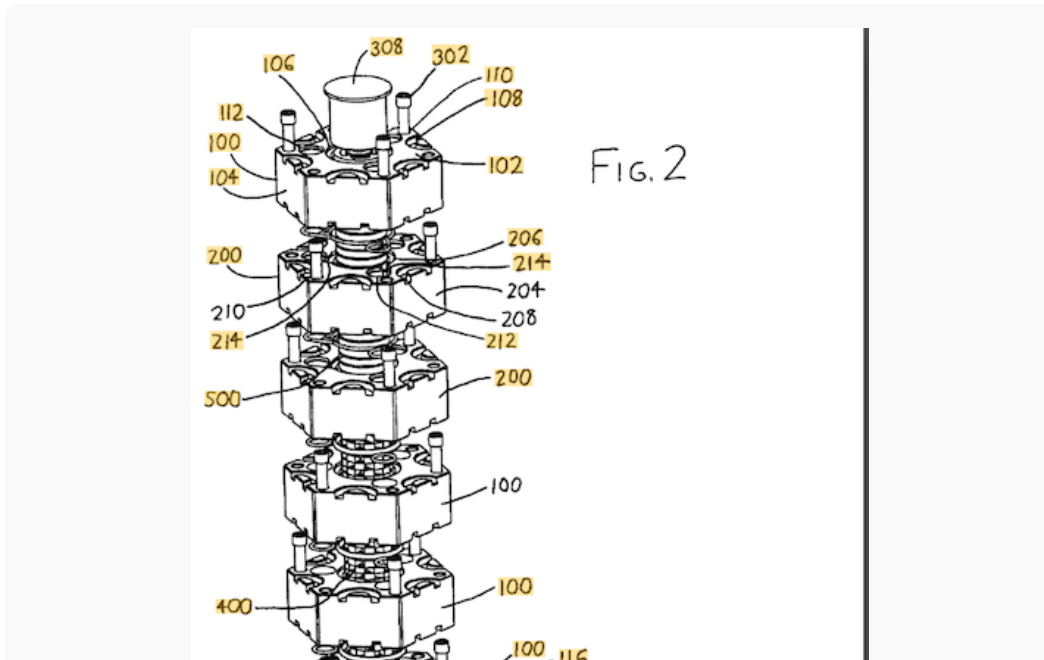

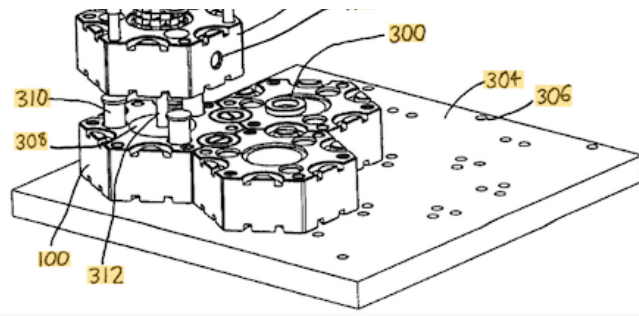

Copyright 6/30/202 Infinity Turbine LLC

SUMMARY OF THE INVENTION

To enhance the reader's understanding, the following summary will make reference to the accompanying FIGS. 1-3, which illustrate an exemplary version of the modular fluid handling device. The device includes a number of blocks—more particularly, fluid passage blocks 100 and fluid intake/outlet blocks 200, as will be discussed below—which each include a block top face 102/202, an opposing block bottom face (not shown), and a series of block sides 104/204 therebetween. The block faces 102/202 are preferably shaped as tessellating regular polygons, whereby the blocks 100/200 may be arrayed together in side-to-side abutting relationship to form a two-dimensional array of blocks (as best seen in FIG. 1). Each block 100/200 includes a central block bore 106/206 extending between the block faces 102/202, whereby the blocks 100/200 may also (or alternatively) be arrayed together in face-to-face abutting relationship to form a stacked array of blocks wherein abutting blocks have their block bores 106/206 coaxially aligned (as seen in the stack of blocks 100/200 shown at the left side of FIGS. 1-3). The foregoing arrangement allows a user to horizontally array and vertically stack blocks 100/200 together into some desired arrangement which is suitable for the user's intended use, e.g., for purposes of experiment, prototyping, or production.

The blocks 100/200 include some means for allowing horizontally adjacent blocks 100/200 to be affixed together, with a preferred horizontal affixment means being best seen in FIG. 3. Here, the block faces 102/202 include semi-annular depressions 108/208 extending from the block sides 104/204, whereby adjacent blocks 100/200 arrayed together in side-to-side abutting relationship may receive an annular side fastener 300 in their adjacent semi-annular depressions 108/208 to affix the adjacent blocks 100/200 together.

The blocks 100/200 additionally include some means for allowing vertically stacked blocks 100/200 to be affixed together, with a preferred vertical affixment means being best seen in FIGS. 2-3. The blocks 100/200 here include face fastener openings 110/210 in their block faces 102/202, with the face fastener openings 110/210 being situated such that blocks 100/200 situated in face-to-face stacked relationship have their face fastener openings 110/210 coaxially aligned. This arrangement allows the blocks 100/200 to be affixed together in face-to-face abutment by extending a fastener 302 between the aligned face fastener openings 110/210 of the abutting blocks 100/200.

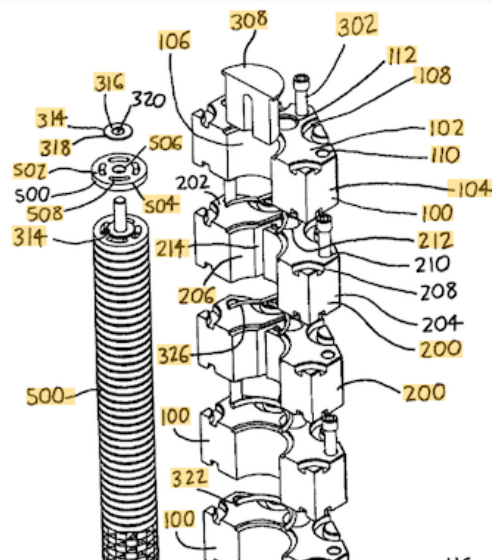

FIG. 3